

your global specialist

Solutions for every wind force.

Speciality lubricants for taxing requirements in
wind power generation





Speciality lubricants – a one-time investment offering long-term benefit	3
Higher performance – lower cost	6
Oil change: How it's done	10
An innovative grease for all bearings	12
Clean solution for the yaw system and pitch open gear	16
Lubricants for enclosed gears	20
Lubricants for bearings	22
Lubricants for open gears and slip rings	24

Speciality lubricants – a one-time investment offering long-term benefit

Wind turbines and their components are exposed to high loads. The constantly changing high loads, vibrations and varying operating conditions require tough equipment. Add to those the external factors such as humidity and extreme temperature variations, and components will really suffer. Wind turbine maintenance is an arduous task and performed only at long intervals, which makes trouble-free operation even harder to accomplish.

Selecting the right lubricant is therefore paramount – for initial lubrication of a component as well as for relubrication during operation.

After all, it is the lubricant that has to ensure reliable operation of each machine element. Both fluids (oils) and consistent lubricants (greases) are used in wind power plants. The main lubrication points are the main gearbox, the nacelle yaw gears, the main and generator bearings, the blade pitch mechanism and the yaw system.

The lubricants used are required to offer reliable performance over a long service life over a wide temperature range as well as resist high load. For operators, these characteristics mean long relubrication intervals for greases and long lubricant life for oils.

What can you do to make your components and installations resist the extremely high stresses in a wind turbine?

Speciality lubricants made by Klüber Lubrication are always a good choice. As an expert in speciality lubricants, Klüber Lubrication cooperates closely with the manufacturers of major components and OEMs to push the limits of what can be technically achieved even further: longer service intervals, longer component life and yet more reliable operation.

Have you ever considered how lubricants can influence your operating costs? The lubricant itself constitutes only a minor investment, but its effects can be tremendous.

Higher performance – lower cost

A high-performance oil for enclosed gears operating under extreme loads

As wind generators get ever larger, the power density in wind turbine gears is increasing, causing higher stress on the gears. Experience has shown that the conventional gear oils available on the market today often fail to meet taxing requirements in terms of wear protection for rolling bearings, micropitting resistance, foam and residue formation, and viscosity stability.

Why use a high-performance gear oil from Klüber Lubrication?

In an effort to overcome the weaknesses of existing products, Klüber Lubrication has developed a gear oil to accommodate the high loads in wind turbine gears.

Compared with standard oils, Klübersynth GEM 4-320 N shows good resistance to load and ageing as well as low friction. It enables long oil change intervals, has lower power losses and provides higher plant yield – by up to several thousand euros over the service life of a wind turbine. It offers excellent antifoaming characteristics and protection against micropitting. It also contains no additives that might promote the formation of residues. Due to its high shear stability, the product's viscosity remains consistent.

Klübersynth GEM 4-320 N meets not only the requirements stipulated by manufacturers of gears, rolling bearings and wind turbines, but those of the operators as well.

Besides an oil's viscosity, it is the additives that protect components reliably against micropitting and scuffing damage, hence enabling longer gear life.

Micropitting is a form of wear occurring on highly loaded gears, especially in the contact area subject to mixed friction and negative specific sliding. Material near the surface is stressed, and micro-cracks form. To the naked eye, the damaged tooth flank area looks greyish. When sufficiently magnified, minute spalling and pores become visible. The principal causes of micropitting are:

- high load
- low gear speed, as this leads to reduced lubricant film thickness
- unfavourable tooth geometry leading to high local loads on the tooth flank
- roughness of the tooth flank
- wrong lubricant

Our high-performance gear oil meets gear manufacturers' requirements in numerous tests

Requirements	Klübersynth GEM 4-320 N
Gear oil acc. to DIN DIN 51517-3	CLP HC
Elastomer compatibility 72 NBR 902	passed
Elastomer compatibility 75 FKM 585	passed
Foam behaviour ASTM D 892	passed
Flender foam test	< 15 %
Fine filtration	possible
FVA 54 IV micropitting resistance, 60 °C	high
FVA 54 IV micropitting resistance, 90 °C	high
FZG scuffing load test DIN ISO 14635-1, A/8,3/90	≥ 14
FZG scuffing load test based on DIN ISO 14635-1, A/16,6/90, failure load stage	≥ 14
FZG wear test DGMK 377-01, wear category	low
FAG FE8 wear test DIN 51819-3, roller wear	< 2 mg
FAG 4-stage bearing test	1.0

Utilise the potential for savings

The following diagram shows the potential savings that can be attained by using synthetic high-performance gear oils. The costs arising from the main gear of an average wind turbine over its entire service life, taking into account oil costs, gear maintenance and gear efficiency, are indicated:

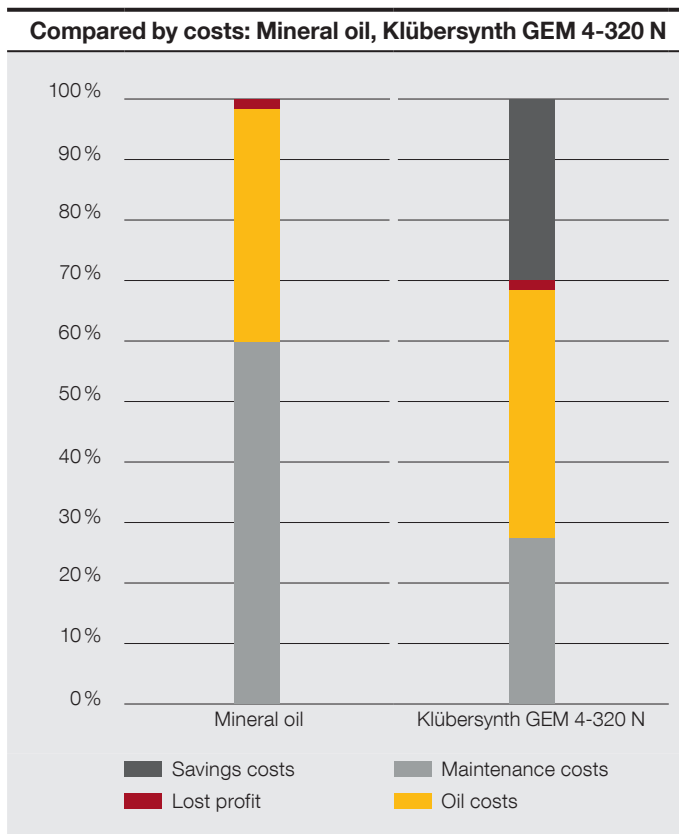

Higher reliability

High micropitting resistance helps prevent premature fatigue damage

Highly loaded gears are susceptible to scuffing and micropitting. High pressure and temperature occurring in the mesh zone can cause tooth damage and consequently lead to premature gear failure. The risk of scuffing or micropitting damage is particularly high with less-than-perfect tooth profiles and surfaces, or where shock loads, vibration, high surface pressures or high sliding friction occur.

Micropitting changes the shape of the tooth flank, which may affect the mesh dynamics and the gear's noise characteristics. The cracks associated with micropitting may propagate, resulting in actual gear pitting.

With its advanced additives, Klübersynth GEM 4-320 N has a high micropitting resistance of load stage \geq LS 10 (GFT-high) in the staged test according to FVA 54/7. In the associated endurance test, micropitting plateaus, showing that the product offers high long-term micropitting protection.

Klübersynth GEM 4-320 N exhibited this high degree of micropitting resistance not only at 90 °C, but also at 60 °C, which is the usual inlet temperature in wind turbine gears

FZG micropitting test (results)

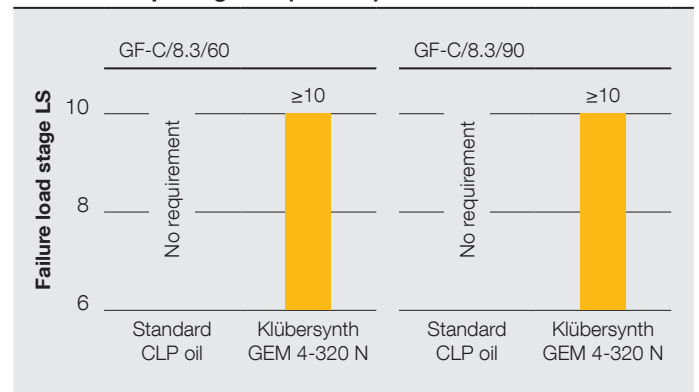

Higher performance – lower cost

In field applications, micropitting formation is often reported even though industrial gear oils with a high micropitting load capacity are used. This is because such oils offer good micropitting resistance as examined in the load stage test.

Klübersynth GEM 4-320 N with its modern additives has shown to prevent propagation of this phenomenon through reaction at the surface of the tooth flanks already affected by micropitting.

Protection against scuffing damage

The FZG scuffing test according to ISO 14635-1 is generally undertaken to test the capability of gear oils to protect against scuffing damage. Load stage \geq LS 12 of the FZG scuffing test is the minimum requirement for CLP oils according to DIN 51517-3, and for EP oils according to AGMA 9005/F16. Klüber Lubrication's gear oils exceed this requirement by a large margin, offering protection at significantly higher scuffing load stages and speeds even under extreme shock load conditions.

FZG scuffing test (results)

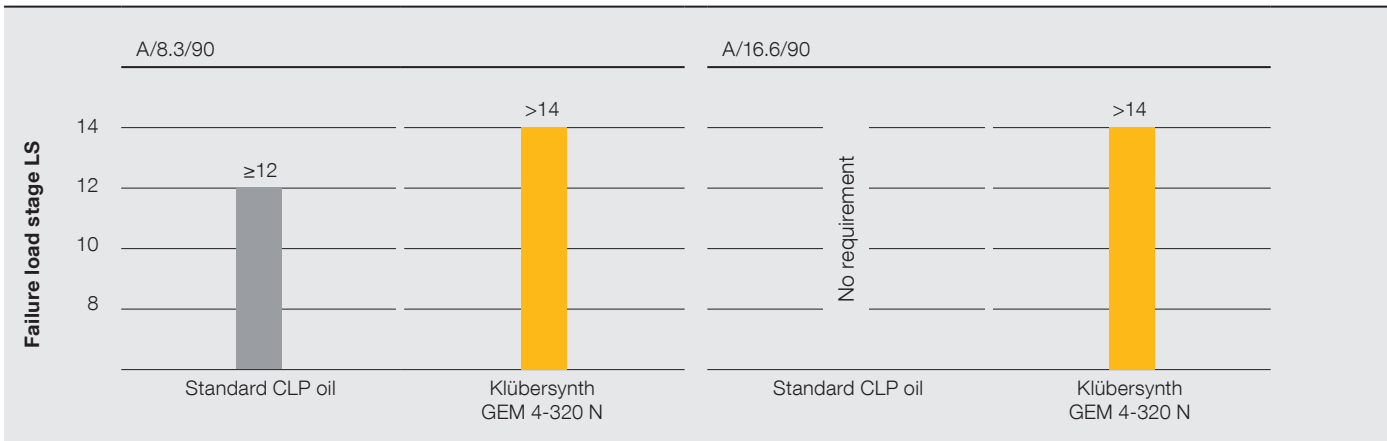

Wear in slow motion

The slow speed wear test C/0,05/60/12 based on DGMK 377-01 determines the wear characteristics of oils under mixed and boundary friction conditions.

The gear oils made by Klüber Lubrication pass the test run with material loss due to wear of less than 40 mg and are therefore classified under the “low” wear category. This is the best possible classification in DGMK 377-01.

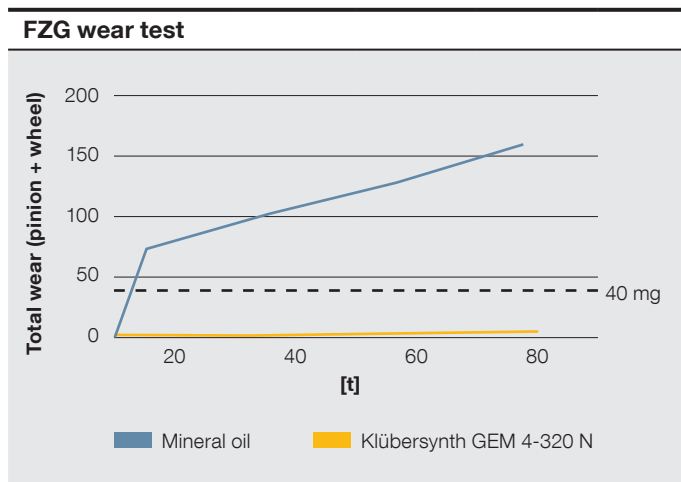

Longer gear life due to adjusted and constant viscosity ratings

The performance a lubricating oil offers are substantially influenced by its additive package and its viscosity. Gear life can be optimised by using synthetic gear oils showing a better viscosity-temperature behaviour.

The viscosity of Klübersynth GEM 4-320 N is considerably more constant than leading competitor oils under varying operating conditions.

Viscosity is of primary importance when selecting gear oils, as it significantly determines the formation of a lubricant film. Increasing viscosity results in thicker lubricant films, thus improving the antiwear and damping properties as well as scuffing load capacity. Viscosity decreases with increasing temperature and rises with increasing load. If the viscosity is too high, increased churning and squeezing losses can result in excessive heat, especially at elevated peripheral speeds. If the viscosity is too low, mixed friction conditions prevail and will result in increased wear.

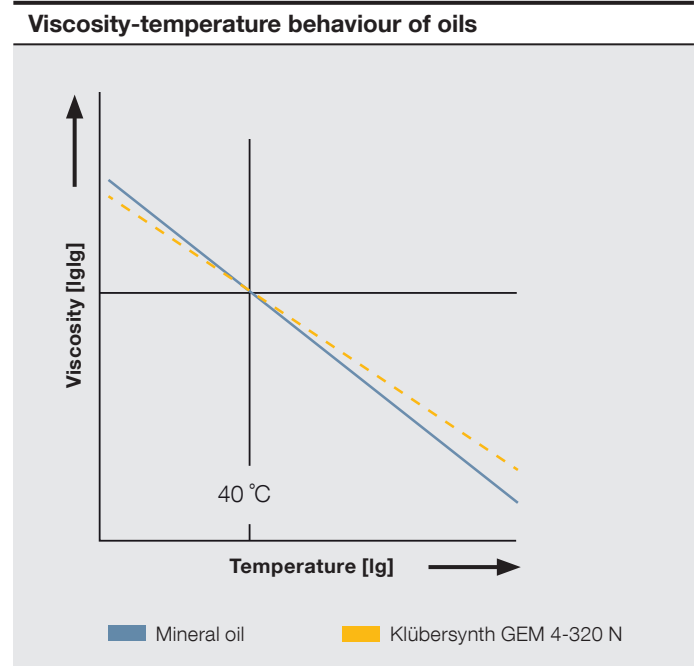

Hint:

A high viscosity index makes for easier start-up at low outside temperatures, reduces power loss to a minimum and ensures the formation of a load-carrying lubricant film also at high temperatures.

Higher performance – lower cost

What's good for gears needs to be good for rolling bearings

Gear damage is frequently associated with damaged rolling bearings. This is why lubricant manufacturers are required to prove that their products are not only suitable for the lubrication of gears, but also for the bearings in the gearbox. Consequently, the standard DIN 51517-3 contains the FE8 rolling bearing test developed by bearing manufacturer FAG. This test serves to determine the wear characteristics of a gear oil and forms the basis of estimating the effect a gear oil has on rolling bearing life. Klübersynth GEM 4-320 N passes the FAG FE8 wear test with very good results, confirming the optimum antiwear effect of this oil.

Thanks to these characteristics, manufacturers and operators of wind turbines can benefit from higher availability and an enormous cost saving potential.

Compatibility with radial shaft elastomer seals

Many complaints regarding gears are raised because of oil leakage. As conventional gear oils are frequently not sufficiently compatible with the seal elastomers, the sealing function can suffer and leakage occurs. High-performance lubricants from Klüber Lubrication were tested with excellent results in combination with numerous materials under dynamic conditions in specialised labs operated by the Freudenberg Group.

Longer gear oil life

As high-performance gear oils from Klüber Lubrication have a longer service life, OEMs can offer gear designs with reduced maintenance requirements. Wind turbine operators have to replace oils and filters less frequently, which results in lower disposal costs. Operators demand gear oils with a long service life. Wind turbine oils are expected to last for more than 20,000 equivalent hours*, which corresponds to an operating time of approx. 6 to 8 years. Standard lubricants specified in various standards do not meet the requirements of the wind energy sector today whereas, in contrast, gear oils from Klüber Lubrication exceed them. Numerous tests show that our gear oils show a low foaming tendency and can thus be fine-filtered.

FAG FE8 wear test (results)

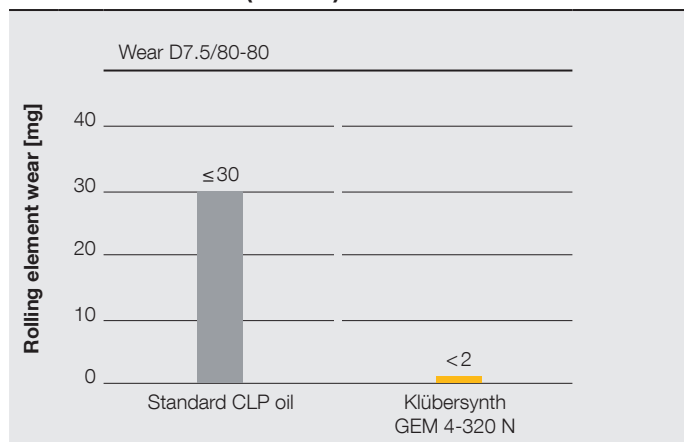

*Equivalent hours is the delivered power divided by the nominal power.
Example: a wind turbine of 1.5 MW that supplies 4,200 MWh a year has 2,800 equivalent hours.

Safe operation and better protection against white etching cracks (WECs)

WECs have been known as a life-reducing failure mode among wind turbine owners and operators, bearing manufacturers and lubricant formulators. Several drivers that potentially cause WEC formation have been reported. These include load, slip, electrical current, water, hydrogen, material inclusions and lubricant additives.

Klüber Lubrication conducts intensive research and testing to evaluate lubricants for safe use in wind turbine components. This large study reveals that additives in Klübersynth GEM 4-320 N offer an excellent protection against WEC. Surface analyses indicate that this is due to its superior tribofilm formation.

WEC bearing test: Surface and sub-surface analysis

WEC-critical oil



Klübersynth GEM 4 N

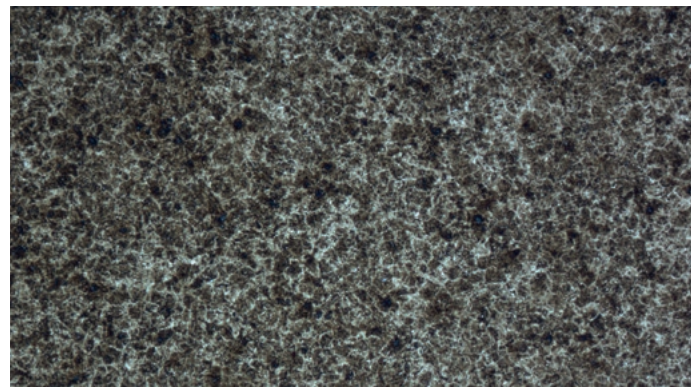
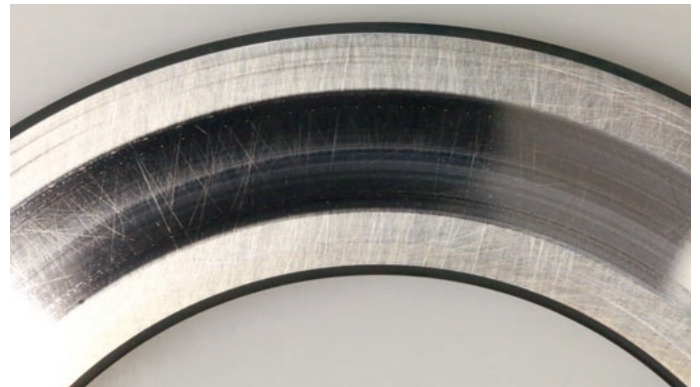

Oil change: How it's done

Oil change

Oil-lubricated enclosed gears require an oil change from time to time since due to the operating and ambient conditions the oil changes its characteristics beyond limits, e.g. in the form of ageing, abrasion and contamination. The objective of the oil change is to ensure continued reliable lubrication. This is also the objective when replacing a gear oil that is basically still fit for use, but not under the prevailing operating conditions.

When an oil change is performed, some residual oil will always remain in the gearbox. In many cases, these residues cannot be tolerated and must be removed. The simplest method is to flush the gearbox. If possible, the old oil is drained while still warm, i.e. immediately after the gears have stopped. With a subsequent flushing procedure, further residues are removed. The oil reservoir and inside gearbox walls can also be cleaned with a lint-free cloth – do not use cleaning wool – and a rubber blade.

A bigger problem is more profound contamination in the form of deposits caused by strongly aged oil. In such cases, cleaning oil has to be used, and all accessible parts of the gearbox cleaned manually. A suitable oil for cleaning gears is Klüber Summit Varnasolv, which quickly dissolves residues when added to mineral oil or PAO. After draining approx. 10% of the gear oil, the oil fill is topped up with Klüber Summit Varnasolv. After 24 to 48 hours of operation, the oil can be drained. Any remaining residues can be removed mechanically.

Klüber Summit Varnasolv HV varnish cleaner

Klüber Summit Varnasolv HV (High Viscosity) is a fluid cleaning concentrate designed to dissolve sticky residues, varnish and carbon build-up during operation and keep them suspended in the oil.

Due to its sufficiently high viscosity matching the gear oil, Klüber Summit Varnasolv HV can be added to the oil to clean gears during operation. At the end of the cleaning process, the used oil is drained to flush out the unwanted residues and fresh, clean oil is applied. Klüber Summit Varnasolv HV is compatible with most mineral and PAO gear oils for wind turbines on the market.

Oil change checklist – Gear inspection

Clean gears	Strongly contaminated gears
Drain oil while warm	Drain approx. 10 percent of the oil fill
Inspect teeth	Top up with Klüber Summit Varnasolv HV
Replace filters	Operate gear for 40 – 60 hours in normal operation
Fill in new oil	Drain oil while warm incl. the oil cooler
Put gear into operation and stop again	Fill flushing oil
Check oil level	Operate gear for approx. 40 to 60 min. without load
Take reference oil sample, if required	Drain flushing oil
	Inspect teeth
	Replace filters
	Fill in new clean and fresh oil
	Put gear into operation and stop again
	Check oil level
	Take reference oil sample, if required

Contaminated gears
Drain approx. 10 percent of oil fill
Top up with Klüber Summit Varnasolv HV
Operate gear for for 40 – 60 hours in normal operation
Drain oil while warm incl. the oil cooler
Inspect teeth
Replace filters
Fill in new clean and fresh oil
Put gear into operation and stop again
Check oil level
Take reference oil sample, if required

An innovative grease for all bearings

Lubrication of main, generator, blade pitch and yaw system bearings

To date, operators of wind power plants frequently have had to obtain different types of grease to suit the varying speeds, loads, sizes and functions of the individual bearings involved. Commonly wind parks contain units from different manufacturers and different models, so various lubricant recommendations have to be followed.

This entails extra expenses for logistics, warehousing and grease disposal, as well as a permanent risk of lubricant confusion. Since most turbines are relubricated manually, service technicians have to carry all these different lubricants with them when on maintenance visits. All required lubricants may also not be always available at certain locations worldwide.

Innovation from Klüber Lubrication: a single grease for all wind turbine bearings

Klüber Lubrication can now serve the differing requirements of all bearings in a wind turbine with a single lubricant consisting of a special base oil mixture and a carefully selected additive package: Klüberplex BEM 41-141 is a speciality lubricant for rolling and plain bearings operating under high loads. It has been developed for

- the wind turbine main bearing, which rotates slowly and is subject to high loads and vibration.
- the relubrication of generator bearings, which run at high speeds and have a high temperature. Initial lubrication takes place at the manufacturer, e.g. with Klüberplex BEM 41-132.
- blade pitch and yaw bearings, which also operate under high loads, vibration and oscillating motion.

Klüberplex BEM 41-141 meets, and even exceeds, today's requirements of bearing and wind turbine OEMs and operators. The lubricant's wide service temperature range, its good pumpability and precise metering in centralised lubricating systems as well as the good grease distribution and oil release ensure trouble-free operation of the wind power plant.

Good wear protection – even under vibration – extends the bearings' service life. Klüberplex BEM 41-141 also helps to prevent the costly damage that tends to arise during standstill. The turbine may be stopped less often, which makes for a significant rise in productivity. The operator's repair and spare parts costs decrease, as does the cost for used grease disposal. With Klüberplex BEM 41-141, the plant operator can restrict his lubricant range to a single grease! This means that lubricant confusion can be eliminated, and storage and logistics are simplified.

Why can Klüberplex BEM 41-141 be used for all bearings?

We have developed Klüberplex BEM 41-141 for the lubrication of bearings in wind turbines, taking into account all critical conditions under which the individual bearings operate. We attached particular importance to the lubricant's performance during standstill and swaying with brakes engaged. These are extremely taxing operating conditions because friction is concentrated on the same point over an extended period of time. In Klüberplex BEM 41-141, the consistency and base oil viscosity were carefully tuned and combined with efficient oil release to enable reliable build-up of a protective lubricant film and excellent grease distribution.

Klüberplex BEM 41-141 testing

In order to satisfy the numerous requirements of bearing manufacturers and plant operators, Klüber Lubrication always performs a variety of tests prior to releasing a grease for specific applications. Besides a large number of static tests, special dynamic rolling bearing tests were performed on Klüberplex BEM 41-141, e.g. the FAG FE8 rolling bearing wear test and the SKF ROF grease life test. All tests showed that this lubricant by far exceeds the requirements of the industry.

Results obtained in SNR-FEB2 rolling bearing grease test

The antiwear behaviour of lubricating greases in rolling bearings subject to small oscillating rolling and sliding motion is determined on the SNR FEB 2 rolling bearing grease tester. Since the wear pattern in this test resembles the indentation caused in the Brinell hardness test, the SNR FEB 2 test is also referred to as “false Brinell test”. An axial load of 8,000 N is applied, corresponding to a Hertzian pressure of 2,100 N/mm², with a frequency of 24 Hz and over an angle of oscillation of $\pm 3^\circ$. The test duration is chosen based on the test temperature: 5 hours for low temperature of -20°C and 50 hours for an ambient test temperature. For a better understanding, we test at -20°C and ambient temperature to see the performance of the greases over a wide range.

Klüberplex BEM 41-141 was tested at ambient temperature resulting in less than 5 mg of wear. The low temperature performance at -20°C resulted in less than 10 mg of wear. Both results show the excellent False Brinelling behaviour of this grease for Wind Turbine applications.

Competitive lubricants available on the market do not reach the excellent results of Klüberplex BEM 41-141.



Competitor product 1: wear limits were exceeded so test had to be stopped after 13.5 hours.



Competitor product 2: wear limits were exceeded so test had to be stopped after 39.6 hours.



Klüberplex BEM 41-141 attained maximum run-time of 50 hours.

Klüber Lubrication also offers tailor-made product solution for every application:

- Klüberplex BEM 41-301 is especially suited for main bearings where a higher base oil viscosity may be required
- Klüberplex BEM 34-131 N, one grease for two applications: generator bearings and blade pitch bearings; it offers extreme corrosion protection
- Klüberbio LG 39-701 N, one grease for two applications: yaw open gear and bearing
- All products are miscible with most products for the wind industry on the market

An innovative grease for all bearings

Low-temperature characteristics of greases

In operation, wind power plants are often subject to huge temperature variations. The very low temperatures are especially tough for the operation of wind turbines. Electric components, plastic and other parts are not designed for temperatures below -10 or -15°C , so turbines without a cold climate package are normally switched off if temperatures drop below these values. Still, the rolling bearing grease has to resist changing under such temperatures, even while the turbine is standing still. As soon as the outside temperatures rise to acceptable levels, the wind power plant restarts. Starting at cold temperatures is often facilitated by a heating system. At the time of start-up, the rolling bearing grease still has to provide its full performance. To make sure the grease is capable of doing so, it has to undergo numerous tests prior to approval.

The lower service temperature of a grease is normally determined by means of the standardised flow pressure test or the low-temperature torque test (IP 186). Upper service temperatures are ascertained on the FE9 rolling bearing tester (DIN 51821) or in the SKF-ROF test. For Klüberplex BEM 41-141, the low-temperature torque test resulted in a lower service temperature of -40°C , and the SKF-ROF test in an upper service temperature of 150°C .

The lower service temperature is the lowest temperature at which the product passed the flow pressure test or the low-temperature torque test. A product's lubricity, however, may not necessarily be sufficient at that temperature and it may not offer sufficient wear protection. This is why Klüber Lubrication has in addition conducted the SNR FEB 2 test to determine the wear characteristics at -20°C .

This test showed that both Klüberplex BEM 41-132 and Klüberplex BEM 41-141 retain their excellent lubricity at very low temperatures. It also demonstrates their outstanding antiwear characteristics. At this temperature, a bearing wear of less than 20 mg was attained with both lubricants – an excellent result.

A special exposure test has shown that both greases Klüberplex BEM 41-132 and Klüberplex BEM 41-141 meet the temperature requirements of the wind energy sector without difficulties – even if they are considerably lower than the grease's nominal lower service temperature. Even at temperature far below zero, the lubricant does not change. And no changes means it offers full performance when the turbine is started again.

Furthermore, Klüberplex BEM 41-132 and Klüberplex BEM 41-141 offer very good adhesion even at extremely low temperatures, which also contributes to good lubrication in the cold. Klüber Lubrication has confirmed adhesion at low temperatures in an especially developed bent-strip test – conducted at temperature conditions considerably below the lower service temperature range.



Hints for practice

What to bear in mind when changing over to a different bearing grease

Comprehensive miscibility tests have shown that Klüberplex BEM 41-141 can be mixed with the bearing greases that are most widely used in the wind power sector today, including those from other manufacturers. No cleaning of the bearing is required prior to changeover. It should be noted, though, that Klüberplex BEM 41-141 will only deliver its full performance benefits when not mixed with other lubricants. For the changeover we recommend therefore relubrication with Klüberplex BEM 41-141 until it can be seen to ooze from the bearing.

Is Klüberplex BEM 41-141 compatible with the seals in contact?

Klüberplex BEM 41-141 is compatible with all elastomers commonly used for seals. Extensive tests in Freudenberg's labs showed that the change of elastomer properties through the contact with this special grease are within permissible limits. The test duration was 28 days at a temperature of 60 °C.

Compatibility of Klüberplex BEM 41-141 with various sealing materials:

80NBRB241	75HNBRU467	85NBRB248
Good	Very good	Very good

Relubrication quantities and relubrication intervals

Quantities and intervals for relubrication are determined by the bearing manufacturer or the wind turbine OEM. However, thanks to the excellent performance of Klüberplex BEM 41-141, the relubrication interval for the generator bearing, for example, can be extended from three or four to more than six months. This means additional flexibility for the operator when it comes to relubrication – there is no more need to stop the turbine for maintenance purposes at a time when the wind is blowing the right way.

Clean solution for the yaw system and pitch open gear

The main problem with the open teeth of the slewing ring and the blade pitch adjustment is that the lubricant can drop off. This leads to insufficient lubrication and eventually higher wear. In addition, the black lubricants that have been used so far cause stains on the nacelle and the tower.

Klüber Lubrication offers Klüberplex AG 11-461/462 (NLGI classes 1 and 2) and Klübersynth AG 14-61, white lubricants for the yaw system and pitch open gear. They retain their good lubricity and remain highly adhesive even at temperatures of -40°C , so they protect the gear teeth reliably against wear. The lubricants' good adhesion leads also to lower grease consumption and longer maintenance intervals.

Klüberplex AG 11-461/462 and Klübersynth AG 14-61 testing

Resistance to salt water

In the SKF Emscor test, Klüberplex AG 11-461/462 and Klübersynth AG 14-61 were tested for their anticorrosive characteristics while exposed to synthetic sea water. The corrosion degree ≤ 2 proves a good anticorrosive effect.

Load-carrying capacity

In the FZG test, Klüberplex AG 11-461/462 and Klübersynth AG 14-61 attain load stage 12, which means that all three products fully meet the requirements for a gear grease.

Low-temperature behaviour

Klüberplex AG 11-461/462 can be pumped using normal spraying systems without heating at temperatures down to approx. 0°C , and Klübersynth AG 14-61 down to -30°C .

Tests in Klüber Lubrication's own test bay have shown that all three products offer better adhesion than traditional black greases at -40°C as well as at high temperatures. In tests performed on a vertical surface at 70°C , none of the three products dropped from the surface even after 48 hours.

Good temperature behaviour

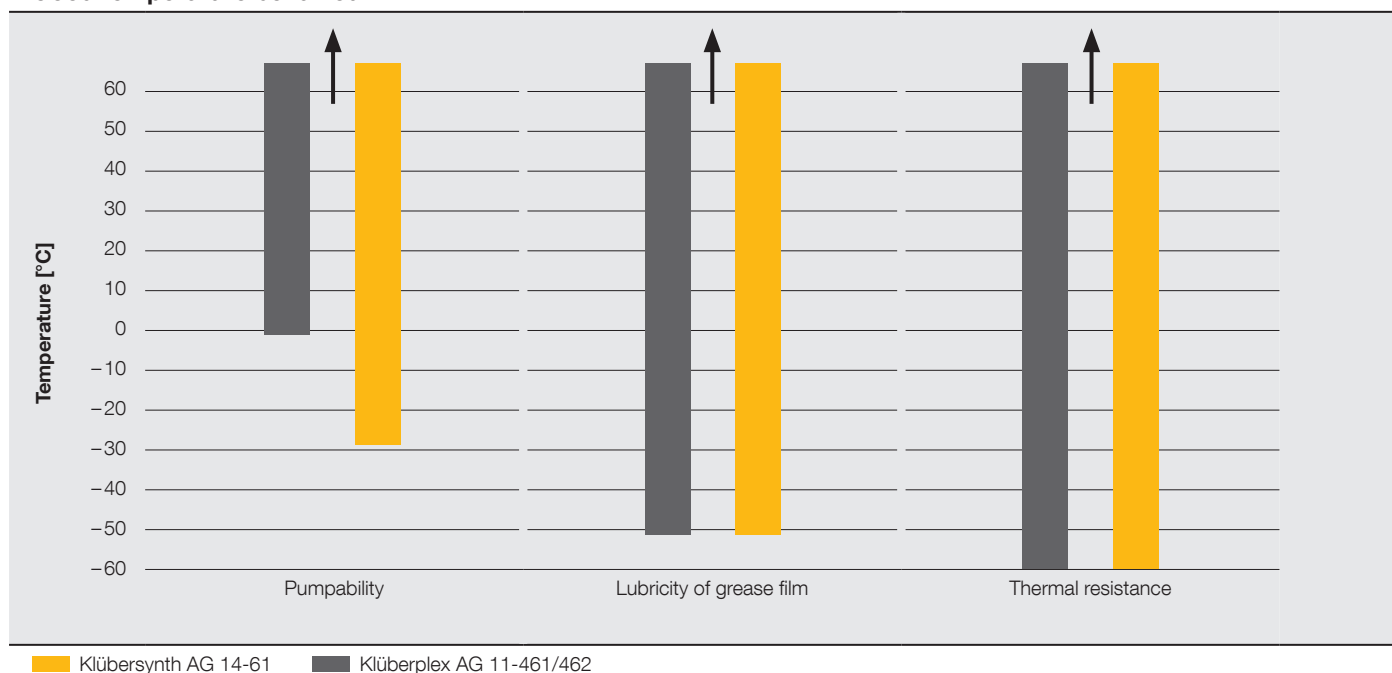



Hints for practice

What to bear in mind when changing over to Klüberplex AG 11-461/462 or Klübersynth AG 14-61

For manual relubrication, the drive components don't have to be cleaned – even if a black lubricant was previously used. When using a centralised lubricating system, however, the storage container should be drained prior to filling with Klübersynth AG 14-61. As is always the case with mixing lubricants, it should be noted that this special grease will only deliver its full performance benefits when not mixed with other lubricants.



Optimally equipped with our speciality lubricants

Main bearing:

Klüberplex BEM 41-141

Klüberplex BEM 41-301

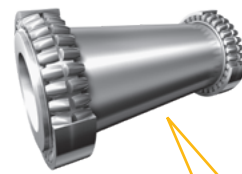

Gear motor:

Klübersynth GEM 4 N

Klübersynth GH 6



Blade pitch bearing:

Klüberplex BEM 34-131 N

Klüberplex BEM 41-141

Blade pitch open gear:

Klüberplex AG 11-461/462

Klübersynth AG 14-61



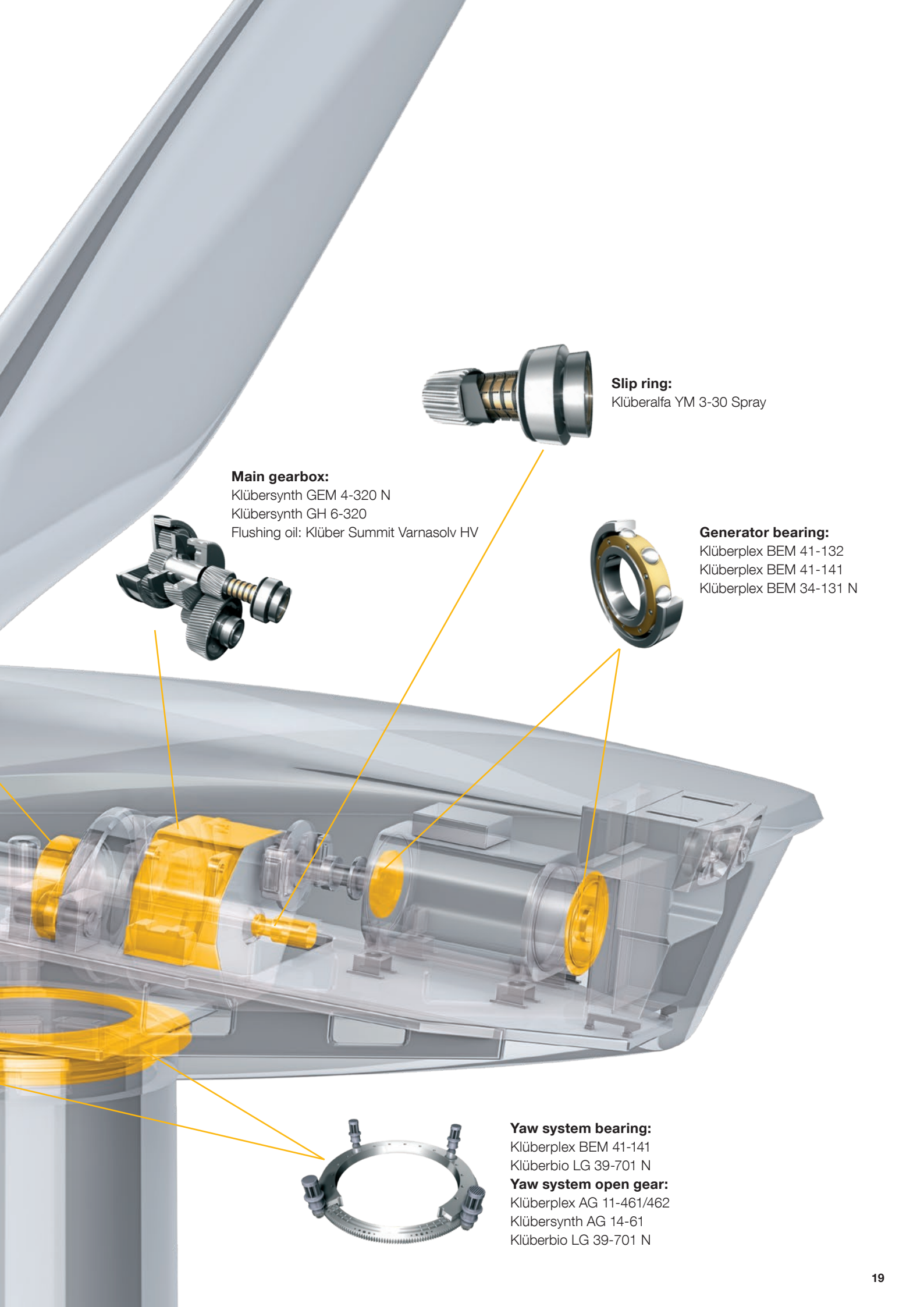



Main gearbox:
Klübersynth GEM 4-320 N
Klübersynth GH 6-320
Flushing oil: Klüber Summit Varnasolv HV

Slip ring:
Klüberalfa YM 3-30 Spray

Generator bearing:
Klüberplex BEM 41-132
Klüberplex BEM 41-141
Klüberplex BEM 34-131 N

Yaw system bearing:
Klüberplex BEM 41-141
Klüberbio LG 39-701 N
Yaw system open gear:
Klüberplex AG 11-461/462
Klübersynth AG 14-61
Klüberbio LG 39-701 N

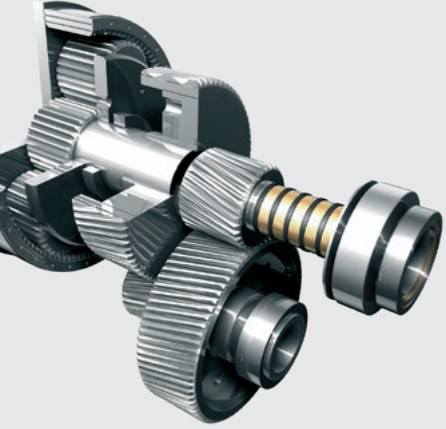
Lubricants for enclosed gears

Component		Requirements
	Main gearbox	<ul style="list-style-type: none">- High scuffing resistance and excellent micro-pitting resistance required- Compatibility with paints and elastomers required- Gear operation depends also on reliability of the rolling bearings. Requirements of rolling bearing manufacturers must therefore also be met
	Gear motors	<ul style="list-style-type: none">- High scuffing resistance and excellent micro-pitting resistance required- Compatibility with paints and elastomers required- Gear operation depends also on reliability of the rolling bearings. Requirements of rolling bearing manufacturers must therefore also be met



Speciality lubricant	Features	Benefits
Klübersynth GEM 4-320 N Klübersynth GH 6-320	<ul style="list-style-type: none"> - Synthetic high-performance gear oil for particularly low and elevated temperatures and high loads - Oil life approx. 5 × longer than that of mineral oil based lubricants 	<ul style="list-style-type: none"> - High FZG scuffing resistance ≥ 14 offers protection at normal and elevated loads - High micro-pitting resistance, both at 90°C and 60°C, protects against premature fatigue failure - Good wear protection prevents premature rolling bearing failure - Dynamic seal compatibility tests with NBR and FKM document protection against oil-induced leakage - Considerably longer service life due to excellent ageing and oxidation resistance, enabling much longer service intervals - Sufficient lubricant film also at high temperatures due to excellent viscosity-temperature behaviour - Good protection of all lubricated parts against wear and scuffing - No filter clogging – lubricated components are supplied with enough clean oil to attain optimum service life
Flushing oil: Klüber Summit Varnasolv HV	<ul style="list-style-type: none"> - Compatible with most mineral and PAO gear oils for wind turbines on the market - Cleaning agent to be added to the gearbox on top of current gear oil before gear oil exchange 	
Klübersynth GEM 4 N Klübersynth GH 6	<ul style="list-style-type: none"> - Synthetic high-performance gear oil for particularly low and elevated temperatures and high loads - Oil life approx. 3 × longer than that of mineral oil based lubricants 	

Lubricants for bearings

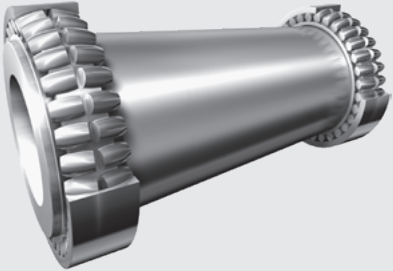
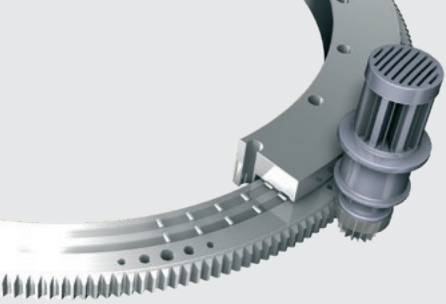
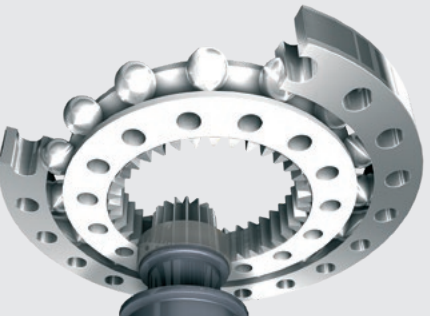
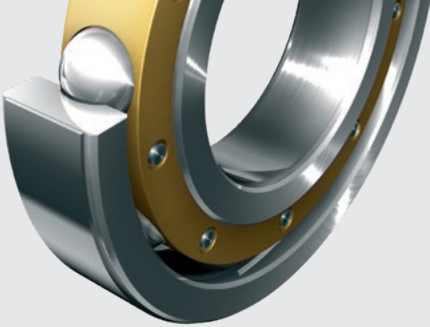
Component		Requirements
	Main bearing	<ul style="list-style-type: none"> - Low speeds - Occasional oscillating motion - High loads - Vibration
	Yaw system bearing	<ul style="list-style-type: none"> - Oscillating motion - High loads - Vibration
	Blade pitch bearing	<ul style="list-style-type: none"> - Oscillating motion - Low temperatures - High loads - Vibration
	Generator bearing	<ul style="list-style-type: none"> - High and low speeds - Occasional oscillating motion - High temperatures - High loads - Vibration



Speciality lubricant	Features	Benefits
Klüberplex BEM 41-141	<ul style="list-style-type: none"> – Wide service temperature range combined with good pumpability and metering in centralised lubricating systems – Good wear protection properties, even under vibration conditions – Good grease distribution and oil separation – High film thickness 	<ul style="list-style-type: none"> – Less downtime, more production time – Reduction of repair and spare parts costs – Simpler logistics due to leaner range of products and less storage
Klüberplex BEM 41-301	<ul style="list-style-type: none"> – Main bearing grease with 300 Cst base oil viscosity, based on same technology as Klüberplex BEM 41-141 – High film thickness – Very long service intervals – Wide service temperature range – Good pumpability 	
Klüberplex BEM 41-141	<ul style="list-style-type: none"> – Wide service temperature range combined with good pumpability and metering in centralised lubricating systems – Good wear protection properties, even under vibration conditions – Good grease distribution and oil separation – High film thickness 	
Klüberbio LG 39-701 N	<ul style="list-style-type: none"> – Biodegradable – For lubrication of the yaw system open gear and the yaw system bearing – Good pumpability in extremely cold climates 	
Klüberplex BEM 41-141	<ul style="list-style-type: none"> – Wide service temperature range combined with good pumpability and metering in centralised lubricating systems – Good wear protection properties, even under vibration conditions – Good grease distribution and oil separation – High film thickness 	
Klüberplex BEM 34-131 N	<ul style="list-style-type: none"> – Very good corrosion protection – Good anti-false brinelling performance – Long service intervals, longer bearing lifetime – Good seal compatibility 	
Klüberplex BEM 34-131 N	<ul style="list-style-type: none"> – Long service intervals – Good relubrication properties – Good pumpability in centralised lubricating systems at low temperature – Good wear protection properties – High film thickness 	
Klüberplex BEM 41-132	<ul style="list-style-type: none"> – Wide service temperature range combined with good pumpability and metering in centralised lubricating systems 	
Klüberplex BEM 41-141	<ul style="list-style-type: none"> – Good wear protection properties, even under vibration conditions – Good grease distribution and oil separation – High film thickness 	

Lubricants for open gears and slip rings

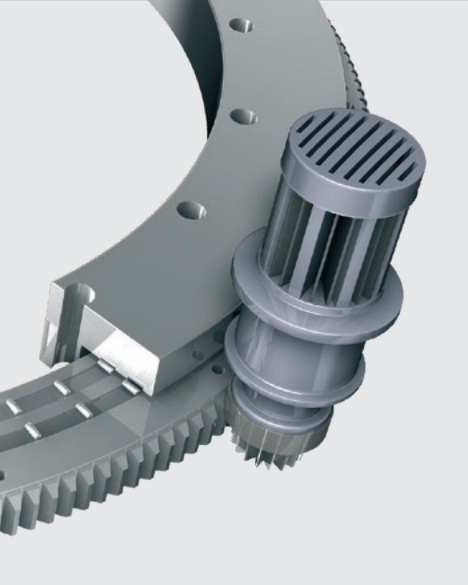
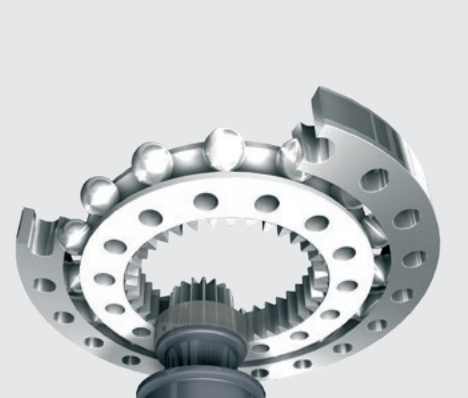
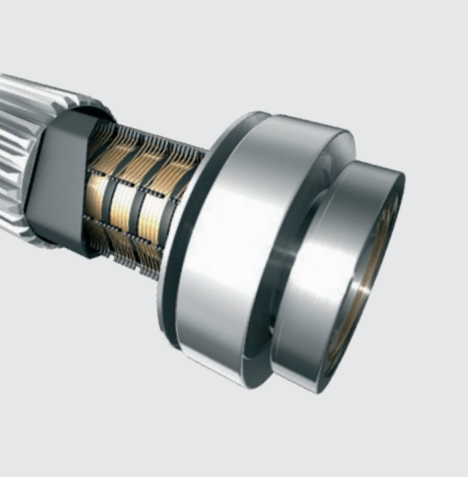
Component		Requirements
	Yaw system open gear	<ul style="list-style-type: none">- Low motion amplitude- High load- Vertical tooth flanks- Tendency towards corrosion
	Blade pitch open gear	<ul style="list-style-type: none">- Low motion amplitude- High load- Vertical tooth flanks- Tendency towards corrosion
	Slip rings	<ul style="list-style-type: none">- Wear and corrosion increase transition resistance



Speciality lubricant	Features and benefits
Klüberplex AG 11-461 Klüberplex AG 11-462 Klübersynth AG 14-61	<ul style="list-style-type: none"> - The products offer good adhesion and do not drop from the tooth flanks, even in the vertical orientation (unlike other lubricants). This reduces lubricant consumption, disposal and nacelle cleaning costs. - Light colour prevents staining of the nacelle and tower. Good pumpability and metering in centralised lubricating systems, hence trouble-free turbine operation and availability. - Anti-corrosive effect provided during non-operation as well as in offshore applications where the nacelle is exposed to salty, humid air. - Klüberplex AG 11-461/462 can be used for large and small open gears.
For yaw open gear and bearing: Klüberbio LG 39-701 N	<ul style="list-style-type: none"> - Biodegradable - Outstanding pumpability in cold climate (down to -30 °C) - With excellent adherence at open gears and lubrication of the yaw bearing
Klüberplex AG 11-461 Klüberplex AG 11-462 Klübersynth AG 14-61	<ul style="list-style-type: none"> - The products offer good adhesion and do not drop from the tooth flanks, even in the vertical orientation (unlike other lubricants). This reduces lubricant consumption, disposal and nacelle cleaning costs. - Light colour prevents staining of the nacelle and tower. Good pumpability and metering in centralised lubricating systems, hence trouble-free turbine operation and availability. - Anti-corrosive effect provided during non-operation as well as in offshore applications where the nacelle is exposed to salty, humid air. - Klüberplex AG 11-461/462 can be used for large and small open gears.
Klüberalfa YM 3-30 Spray	<ul style="list-style-type: none"> - Longer contact life and equipment availability as Klüberalfa YM 3-30 protects the contact against harmful influences. - Klüberalfa YM 3-30 Spray is a slip-ring oil with long-term resistance and a particular low base oil viscosity. Spray application is particularly even, simple and clean, making for low-maintenance operation.





Publisher and Copyright:

Klüber Lubrication München SE & Co. KG

Reprints, total or in part, are permitted only prior consultation with Klüber Lubrication München SE & Co. KG and if source is indicated and voucher copy is forwarded.

The data in this document is based on our general experience and knowledge at the time of publication and is intended to give information of possible applications to a reader with technical experience. It constitutes neither an assurance of product properties nor does it release the user from the obligation of performing preliminary field tests with the product selected for a specific application. All data are guide values which depend on the lubricant's composition, the intended use and the application method. The technical values of lubricants change depending on the mechanical, dynamical, chemical and thermal loads, time and pressure. These changes may affect the function of a component. We recommend contacting us to discuss your specific application. If possible we will be pleased to provide a sample for testing on request. Products from Klüber Lubrication are continually improved. Therefore, Klüber Lubrication reserves the right to change all the technical data in this document at any time without notice.

Klüber Lubrication München SE & Co. KG

Geisenhausenerstraße 7

81379 München

Germany

Local first-instance court Munich, Germany

Certificate of registration 46624

Picture Copyrights:

Title: © Majeczka, www.shutterstock.com;

Page 2: © Uwe Bumann, www.fotolia.com;

Page 26: © JJS, www.fotolia.com

www.klueber.com

Klüber Lubrication – your global specialist

Innovative tribological solutions are our passion. Through personal contact and consultation, we help our customers to be successful worldwide, in all industries and markets. With our ambitious technical concepts and experienced, competent staff we have been fulfilling increasingly demanding requirements by manufacturing efficient high-performance lubricants for more than 85 years.